

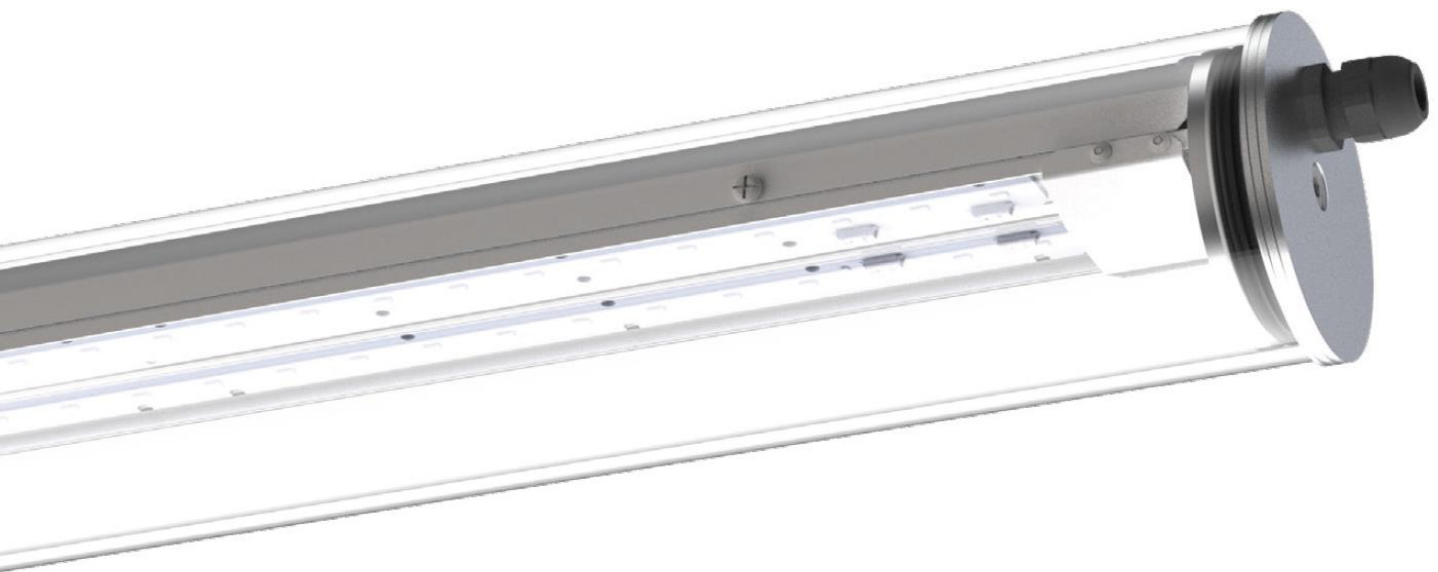

INSTALLATION AND MAINTENANCE MANUAL FOR  
LIGHT FITTING

# INS242LED



Carefully read the instructions before  
mounting the light fitting.

## TABLE OF CONTENTS

1. GENERAL INFORMATION.....	3
2. TECHNICAL INFORMATION.....	4
3. PHOTOMETRICAL DATA.....	5
4. CONSTRUCTION .....	5
5. PRELIMINAIRES .....	5
6. INSTALLATION .....	6
7. ELECTRICAL CONNECTION.....	6
8. CONDITIONS FOR SAFE USE .....	7
9. MAINTENANCE AND SERVICING .....	7
10. SPARE PARTS.....	8
11. REPAIRING .....	8
12. LIGHT SOURCE EXCHANGE .....	8
13. TRANSPORT AND CONDITIONS OF STORAGE.....	8
14. DISPOSAL OF WASTE EQUIPMENT .....	8
15. WARRANTY.....	8

## 1. GENERAL INFORMATION

Tubular luminaire with LED modules. Housing made of borosilicate glass or polycarbonate. Very high degree of protection IP69K. The luminaire is equipped with special optics that disperse the luminous flux of the modules.

I N S 2 4 2 L E D -								E -		P 20 -				- AMO1	
<b>group</b> industrial light fittings		0	6	0	0	J	1	0	1	1	30	10	GL	NIRO	AMOX
<b>type</b> type 242		1	2	0	0	B	2	1	3	5	33	11	PC	316	AMOY
<b>source of light</b> LED modules						D	4	3					PMMA	ALU	
<b>approximate length</b> ~ 600mm, 1200mm															
<b>LED modules type</b>															
<b>LED modules quantity</b>															
<b>power supply</b> 11E - 24 VDC 35E - 230V, 0/50+60Hz															
<b>wiring</b> 30 - single 3-pole terminal → <input type="text" value="3"/> ← 33 - double 3-pole terminal → <input type="text" value="3"/> <input type="text" value="3"/> ←															
<b>cable inlets - quantity</b> 10 - one cable inlet in one endcap → <input type="text" value="1"/> <input type="text" value="0"/> ← 11 - one cable inlet in both endcaps → <input type="text" value="1"/> <input type="text" value="1"/> ←															
<b>cable inlets - material</b> P - plastic															
<b>cable inlets - size</b> 20 - Ø20															
<b>tube material</b> GL - tempered glass PC - polycarbonate PMMA - polymethyl methacrylate															
<b>endcap material</b> NIRO - stainless steel 316 - austenitic chrome-nickel stainless steel ALU - aluminum															
<b>mountings</b> AMO1 AMOX AMOY															

Risk group of used LED Modules RG = 1.

## 2. TECHNICAL INFORMATION

Type	Power	Voltage	IP	Protection class	Power factor	Ambient temperature
INS242LED-0600-J1-3	13,8 W	230V 0,50,60 Hz	69K	I	≥0,95	-25 do +45°C
INS242LED-0600-J2-1	18,5 W					-25 do +45°C
INS242LED-0600-J2-3	26,4 W					-25 do +40°C
INS242LED-1200-B2-1	35,7 W					-25 do +45°C
INS242LED-1200-B2-3	51,6 W					-25 do +40°C
INS242LED-1200-B4-1	70,4 W					-25 do +40°C
INS242LED-0600-D1-0	9,6 W	24V 0 Hz		III	-	-25 do +45°C
INS242LED-0600-D2-0	19,2 W					-25 do +45°C
INS242LED-1200-D4-0	38,4 W					-25 do +45°C

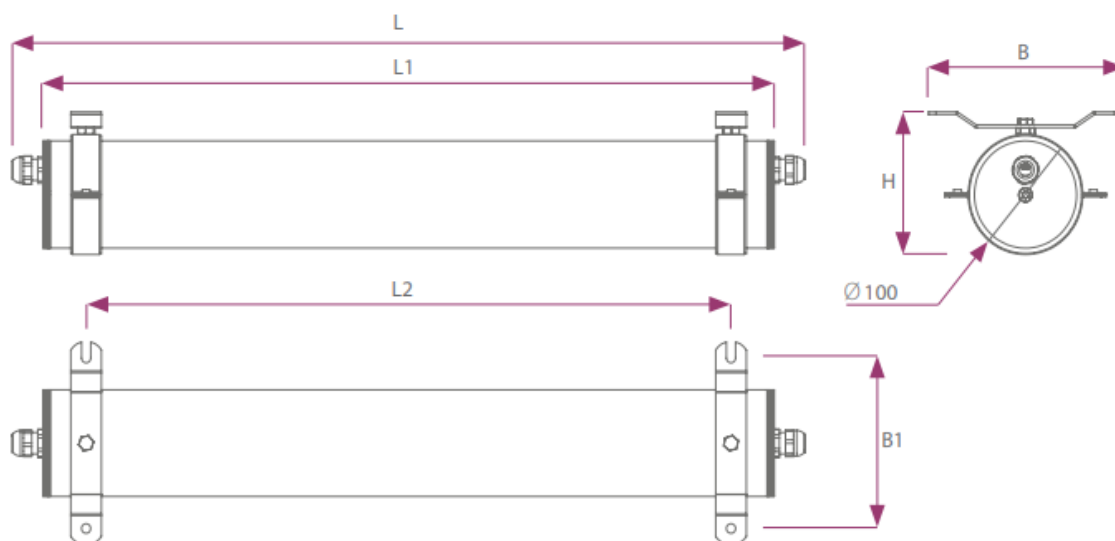

TYP   TYPE	L	L1	L2	B	B1	B2
INS242LED-0600	776	716	nastawny/adjustable	190	160	135
INS242LED-1200	1336	1276	nastawny/adjustable	190	160	135

### 3. PHOTOMETRICAL DATA

Type	Luminous flux	Efficiency	Colour temperature	CRI	Lifetime
INS242LED-0600-J1-3	1826 lm	132 lm/W	4000K 5000K 6500K	>80	>70000 h
INS242LED-0600-J2-1	2622 lm	142 lm/W			
INS242LED-0600-J2-3	3652 lm	138 lm/W			
INS242LED-1200-B2-1	5243 lm	147 lm/W			
INS242LED-1200-B2-3	7305 lm	142 lm/W			
INS242LED-1200-B4-1	10487 lm	149 lm/W			
INS242LED-0600-D1-0	1330 lm	138 lm/W			
INS242LED-0600-D2-0	2660 lm	138 lm/W			
INS242LED-1200-D4-0	5319 lm	138 lm/W			

Lifetime of LED modules: L<sub>80</sub>B<sub>10</sub>

### 4. CONSTRUCTION

The body is made of borosilicate glass, PMMA or PC. Endcaps are made of aluminum or stainless steel. The mounting plate is made of powder-coated galvanized steel sheet.

### 5. PRELIMINAIRES

#### SAFETY RULES

- Before starting the installation of the lighting fixture, carefully read all the information contained in these operating instructions,
- Adhere to the general safety rules,
- Violating of the rules concerning assembly and use may lead to personal injury or property damage. ATM Lighting sp.z o.o. is not responsible in such cases,
- Failure to comply with the recommendations contained in this manual voids the manufacturer's warranty.

#### NECESSARY TOOLS

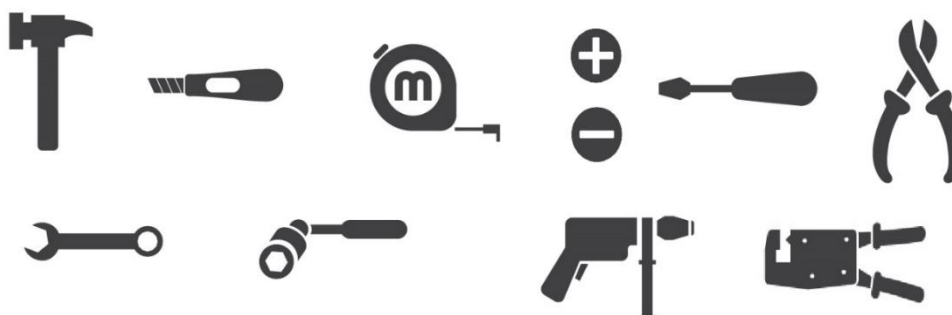

## 6. INSTALLATION

The INS242LED luminaire is equipped with an adjustable bracket. Mounting holes in the bracket have Ø9mm holes. Dimensional details can be found in point 2 of this manual.

## 7. ELECTRICAL CONNECTION

In order to connect the power supply:

- unscrew the endcap (one socket head cap screw) and then remove it from the housing.
- insert the power cord into the luminaire, through the cable entry (gland),
- carefully strip the cable cores (8-10mm), and then insert it into the connector according to the marking inside the luminaire,
- tightly clamp the power cord in the gland using 2 wrenches,
- check the effectiveness of earthing.
- install endcap and check for proper sealing.

Electrical connection scheme 230V:

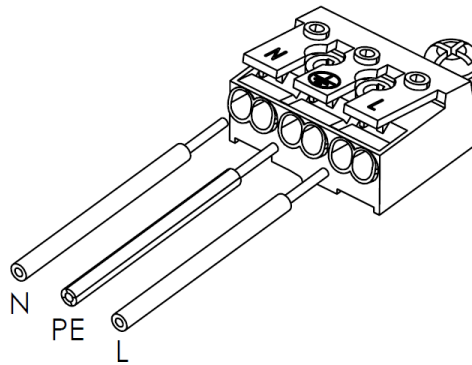

Electrical connection scheme 24V (III class):

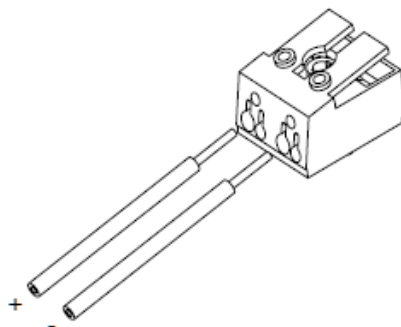

Notice:

- Use one wrench to tighten the gland packing nut while securing the gland body against twisting with the other wrench.
- Failure to comply with the above caution may damage the sealants, thus reducing the degree of tightness.



- Do not stare at the working light source



- Risk of electrical shock

## 8. CONDITIONS FOR SAFE USE

- Each luminaire has a nameplate with technical data. Each luminaire has an operating and operating manual that should be kept until the end of the luminaire's life.
- Luminaires are suitable for fixed installations only.
- Operation of the luminaire outside the designated operating temperature range will lead to faster wear and / or damage to it. At the same time, I void the manufacturer's warranty.
- Each luminaire must have a warning label that reads: "DO NOT OPEN WHILE POWERED".
- 3-core cables (with PE wire) with a maximum outer diameter of 8-13mm should be used as power cables.
- Use power conductors with a cross-section of 0.5-1.8mm<sup>2</sup>.
- Maximum load on through conductors I = 16A
- Depending on the version, the lampshade of the luminaire is made of polycarbonate, therefore it should not be exposed to chemicals that may damage it, in particular: oil, acetone, chlorine, ethyl, ether, solvents. If there is any uncertainty about the substances present in the luminaire's workplace, which may lead to damage to any of the components, steps should be taken to determine what is appropriate.

## 9. MAINTENANCE AND SERVICING

**REMARK:** during the servicing and maintenance touching of LED are prohibited, because it will decrease the lifetime of light fitting and cause the loss of manufacturer's warranty.

**INSPECTION:** at least once a month. Inspection is made without opening the light fitting. User must check admission cables condition (insulation damage, cracks, burns etc.). Cables must not have any acute bends. Outside parts of the light fitting must be checked. No cracks or corrosion signs may occur. Bolts used to mount light fitting should be properly tightened, washers mustn't be cracked. Cleanliness of outer surfaces and light fittings surroundings must be checked. Light fittings may not be soiled by paint or grease. Do not allow for dust (dirt) deposition on the light fitting. The readability of rating and warning plates must be checked. Abnormalities found must be fixed.

**SERVICE AND MAINTENANCE:** at least once a year. Service and maintenance must be made with power supply turned off. User must make inspection steps first. After opening: metal parts painting, condition of inner wiring and its mounting, insulating materials, cable glands gaskets, terminals. Abnormalities found must be fixed. Rating and warning plates must be cleaned. Surfaces of insulating materials and covers must be clean.

**VERIFICATION OF TECHNICAL CONDITION:** at least once for 2 years. Power supply must be switched off. Light fitting must be uninstalled. Besides all the examination from inspection, service and maintenance paragraphs electrical examination from the inspection, service and maintenance paragraphs electrical examination must be also made: light fitting current consumption, insulation examination, protective earthing condition. Special attention must be paid to insulating parts condition. No crack or burns may occur.

**CLEANING:** do not allow for dust (dirt) deposition on the light fitting. Cleaning must be proceeded without use of chemical. Cleaning must be proceeded with use of compressed air and soft cleaning cloth or soft brush. If necessary use water and/or neutral detergent, however without any chemicals, which can damage any part of the light fitting.

## 10. SPARE PARTS

All parts considered as a spare parts must be ordered at manufacturer of light fitting.

## 11. REPAIRING

All repairs may be made only by manufacturer or authorized repair workshops.

## 12. LIGHT SOURCE EXCHANGE

Lamps exchange may be made only by specially trained personnel using the original components provided by ATM Lighting sp. z o.o.

## 13. TRANSPORT AND CONDITIONS OF STORAGE

During transport light fittings shouldn't be exposed to precipitation or mechanical shock.

Light fittings may be storage only in sheltered warehouses, within +5°C to +35°C temperature range, and relative humidity lower than 75%. No corrosion causing vapors or gases should be PRESENT.

## 14. DISPOSAL OF WASTE EQUIPMENT

User must obey relevant rules and regulations about disposal of wasted equipment valid in their country.

## 15. WARRANTY

- It is forbidden to use a damaged or malfunctioning luminaire. Installation checks must be carried out to detect any anomalies.
- It is required to disconnect power from the luminaire before carrying out any maintenance.
- It is not allowed to make changes to the luminaire structure on your own. Any unauthorized interventions may reduce the functionality or damage the device, and in special cases may pose a threat to life or health. At the same time, it releases the manufacturer from any warranty liability.



- Detailed information can be found in the document "General warranty conditions of ATM Lighting sp. Z o.o." available at [www.atmlighting.pl](http://www.atmlighting.pl)





**ADDRESS:**

**ATM Lighting sp. z o.o.**

ul. Maszynowa 30A 80-298 Gdańsk

tel: +48 58 347 51 07 fax: +48 58 347 51 08

office[atmlighting].pl