







INSTALLATION AND MAINTENANCE MANUAL FOR LIGHT FITTING

INS350LED

 -40°C	 +60°C	C4	CHEMICALLY RESISTANT NH ₃	NIRO	ENCAPSULATED LED
IP67	IP68	 EASY CLEANING	24 VDC	OPTIONAL CENTRAL BATTERY	CONTROL SYSTEM 

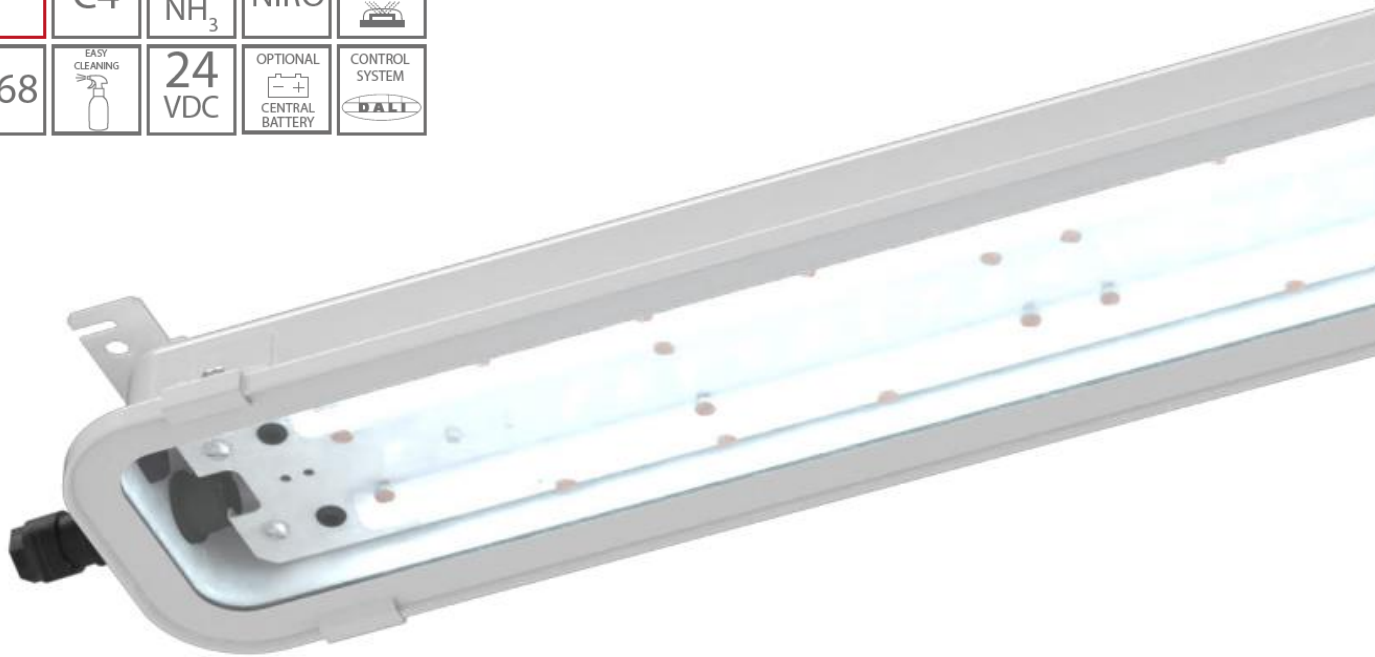

It is required to get to know this manual before
installation.

TABLE OF CONTENTS:

1. GENERAL INFORMATIONS.....	3
2. TECHNICAL DATA.....	4
3. PHOTOMETRICAL DATA.....	4
4. CONSTRUCTION DESCRIPTION.....	5
5. PRELIMINAIRES	5
6. LIGHT FITTING MOUNTING.....	5
7. ELECTRICAL CONNECTION.....	7
8. CONDITION OF SAFETY USE.....	7
9. LIGHT FITTING MAINTENANCE AND SERVICING	8
10. PARTS EXCHANGE.....	9
11. TRANSPORT AND CONDITIONS OF STORAGE.....	9
12. DISPOSAL OF WASTE EQUIPMENT.....	9
13. WARRANTY.....	9

1. GENERAL INFORMATIONS

Dustproof and waterproof industrial luminaire with encapsulated LED modules designed for heavy operating conditions. Housing made of stainless steel with increased acid resistance, diffuser made of tempered glass type "Safety glass", PC or PMMA. Possibility of making DA version with an integrated power supply with DALI interface or adapting the light fitting to work with the ZB central battery.

I	N	S	3	5	0	L	E	D	-	-	-	-	E	-	RST	25	NIRO	-	-	-	-	-	AMO6	
group industrial light fittings	0	6	0	0						J	2	1	35	20	10									AMO1
type type 350	1	2	0	0						B	4	3	11	22	11									AMO2
source of light LED modules										D				30	20									AMO3
approximate length – 600mm, 1200mm														33	22									AMO7
LED module type														50								ASY		
LED modules quantity														55										
driving current																								
input voltage 35E - 220-240V, 0/50+60Hz 11E - 24V, 0Hz																								
wiring 20 - single 2-pole terminal → 2 22 - double 2-pole terminal → 2 2 ← 30 - single 3-pole terminal → 3 33 - double 3-pole terminal → 3 3 ← 50 - single 5-pole terminal → 5 55 - double 5-pole terminal → 5 5 ←																								
cable inlets - quantity 10 - one cable inlet on the side of the housing → 1 0 11 - one cable inlet on each sides of the housing → 1 1 ← 20 - two cable inlets on one side of the housing → 2 0 22 - two cable inlets on both sides of the housing → 2 2 ←																								
cable inlets - type RST - plug and socket																								
cable inlets - size 25 - plug and socket Ø25																								
housing material NIRO - powder coated stainless steel																								
diffuser material PC - polycarbonate PM - PMMA poly(methym methacrylate) GL - tempered glass SGL - safety-glass (tempered glass with foil layers between)																								
optional optics version C5 - version adapted to work in a high corrosive environment C5. All the external parts are made of stainless steel. LED modules are encapsulated, which provide high lifetime. The encapsulated LED modules cannot be equipped with additional optics. NB - narrow beam optics MB - medium beam optics WB - wide beam optics ASY - asymmetrical beam optics																								
protection class III protection class is available only with D modules (input voltage 24V, 0Hz)																								
optional versions DA - light fitting equipped with integrated driver with DALI-2 protocol ZB - version adapted to work with central battery. Luminous flux for ZB version equals 50% of the nominal luminous flux value.																								
mounting check: mountings Standard bracket: AMO6																								

2. TECHNICAL DATA

Type	Power supply	Voltage and frequency	IP	Protection class	Power factor	Ambient temperature
INS350LED-0600-J2-1	18,2 W	230V 0,50-60Hz	67/68	I	≥0,97	-35 do +60°C
INS350LED-0600-J2-3	25,7 W					-35 do +50°C
INS350LED-1200-J4-1	34,5 W					-35 do +60°C
INS350LED-1200-J4-3	49,1 W					-35 do +50°C
INS350LED-1200-B4-1	57,8 W					-35 do +40°C
INS350LED-0600-D2	23,5 W	24VDC, 0Hz		III		-35 do +60°C
INS350LED-1200-D4	45,0 W					-35 do +60°C

Risk group of used modules LED RG = 1.

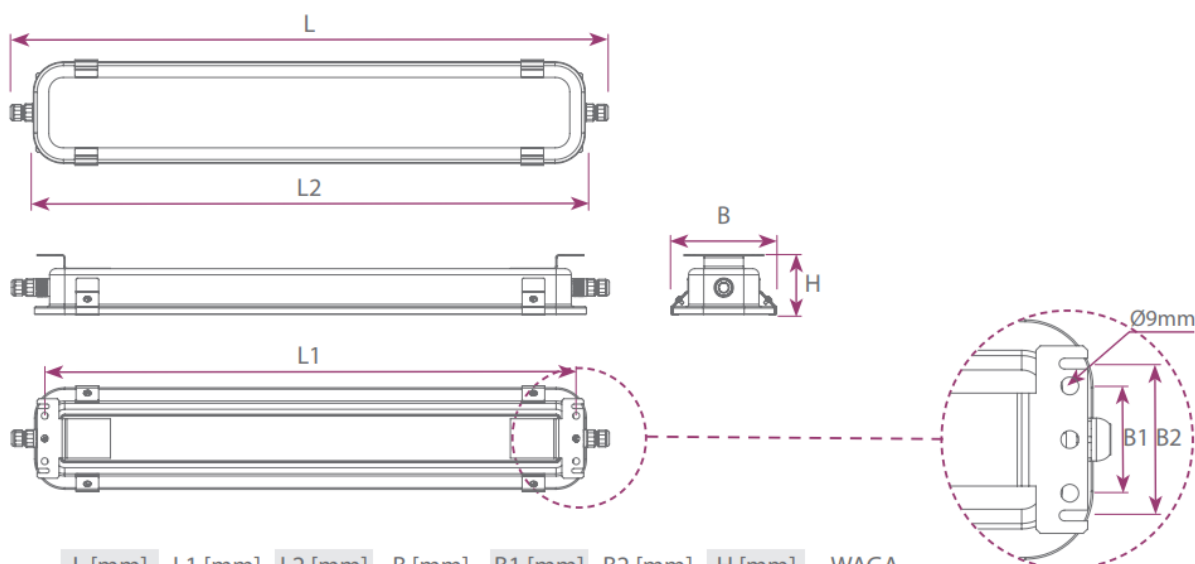

TYP	L [mm]	L1 [mm]	L2 [mm]	B [mm]	B1 [mm]	B2 [mm]	H [mm]	WAGA
INS350LED-0600	853	704	730	139	60	85	80	4,7kg
INS350LED-1200	1463	1314	1340	139	60	85	80	7,2kg

3. PHOTOMETRICAL DATA

STANDARD VERSIONS (OPTICS NB, MB, WB)

Type	Luminous flux	Efficiency	Colour temperature	CRI	Lifetime
INS350LED-0600-J2-1	2700 lm	148 lm/W	4000K	>80	>70000 h
INS350LED-0600-J2-3	3700 lm	144 lm/W			
INS350LED-1200-J4-1	5390 lm	156 lm/W			
INS350LED-1200-J4-3	7500 lm	153 lm/W			
INS350LED-1200-B4-1	9300 lm	161 lm/W			

Modules lifetime LED: L₈₀B₁₀

STANDARD VERSION (OPTICS ASY)

Type	Luminous flux	Efficiency	Colour temperature	CRI	Lifetime
INS350LED-0600-J2-1	2600 lm	148 lm/W	4000K	>80	>70000 h
INS350LED-0600-J2-3	3700 lm	144 lm/W			
INS350LED-1200-J4-1	5300 lm	156 lm/W			
INS350LED-1200-J4-3	7300 lm	153 lm/W			
INS350LED-1200-B4-1	9100 lm	161 lm/W			
INS350LED-0600-D2	2500 lm	106 lm/W			
INS350LED-1200-D4	5000 lm	111 lm/W			

Modules lifetime LED: L₈₀B₁₀

4. CONSTRUCTION DESCRIPTION

Housing is made of powder painted galvanized or stainless-steel sheet. Diffuser is made of UV stabilized polycarbonate, tempered glass or PMMA. Mounting tray is made of powder painted galvanized steel sheet. Safety clamps are made of stainless steel.

5. PRELIMINAIRES

CONDITIONS OF SAFETY RULES

- Carefully read all the information included in the manual before mounting the light fitting.
 - General safety must be applied.
 - Failure to comply with rules of the installation and use can lead to personal injury or property losses. Company ATM Lighting sp. z o.o. takes no responsibility in such cases.
- Failure to comply with rules included in manual results with void of the manufacturer warranty.

6. LIGHT FITTING MOUNTING

Depends on versions of fixing there are few ways it can be mounted:

1. Light fitting equipped with **AMO1**.

Light fitting is mounted with use of two brackets, designed for direct installation on a ceiling or on a wall.

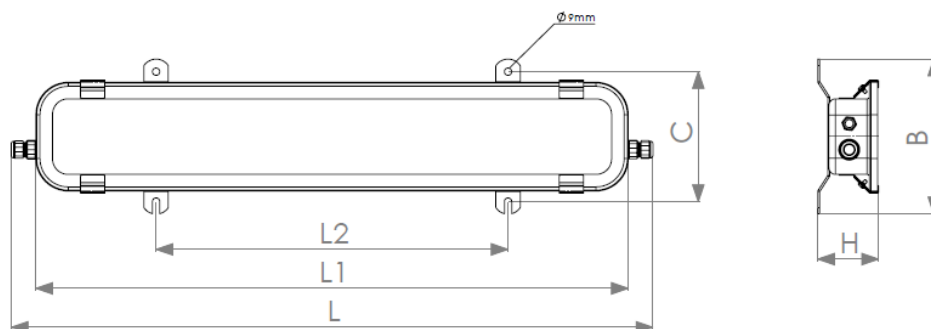

Type	L	L1	L2	B	H	C
INS350LED-0600	790	730	430	153	80	119
INS350LED-1200	1400	1340	950			

2. Light fitting equipped with **AMO3**.

Light fitting is mounted with use of two clamps designed for installation on a pipe.

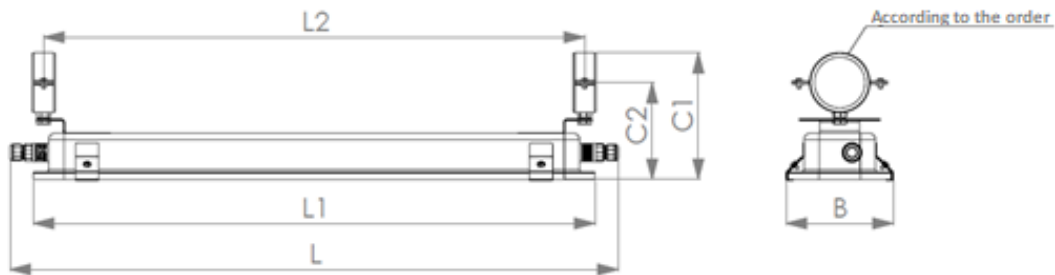

Type	L	L1	L2	B	C1	C2
INS350LED-0600	790	730	704	139	165	126
INS350LED-1200	1400	1340	1314			

3. Light fitting equipped with **AMO6**.

Luminaire is mounted with use of two brackets, designed for direct installation on a ceiling.

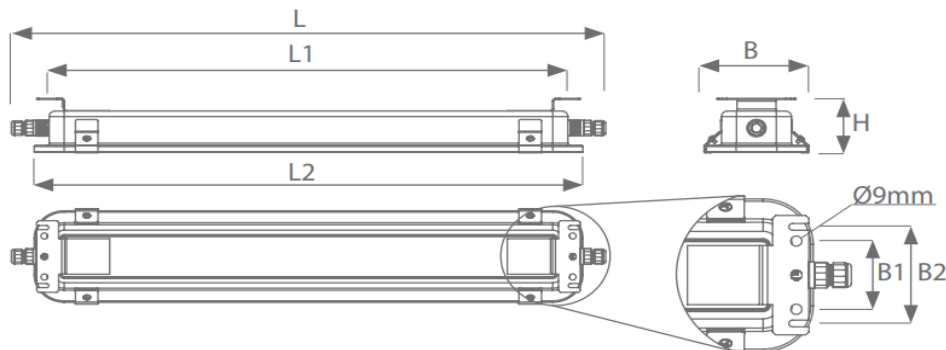

Type	L	L1	L2	B	B1	B2	H
INS350LED-0600	790	704	730	139	60	85	80
INS350LED-1200	1400	1314	1340				

4. Light fitting equipped with **AMO7**.

Light fitting is mounted with use of two brackets, designed for direct installation on pipe.

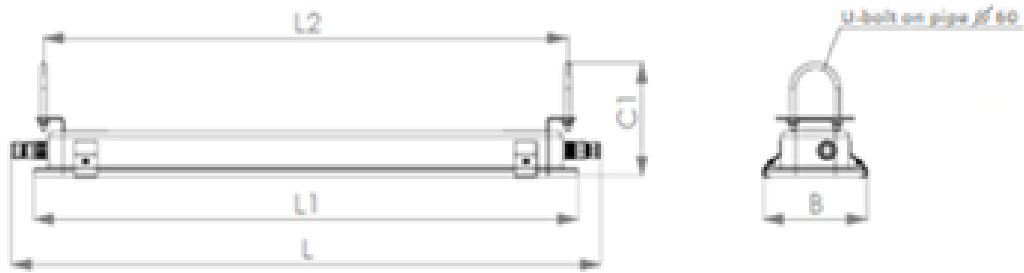

Type	L	L1	L2	B	C1
INS350LED-0600	790	730	704	139	151
INS350LED-1200	1400	1340	1314		

7. ELECTRICAL CONNECTION

To connect power supply:

- enter the power cable to the housing through the built-in socket-plug (RST),
- carefully unisolate the cables cores (8-10mm), and put it into the built-in socket-plug according to marking inside the light fitting,
- precisely tighten power cable in the gland with two wrenches,
- check the effectiveness of grounding.

Power connection:

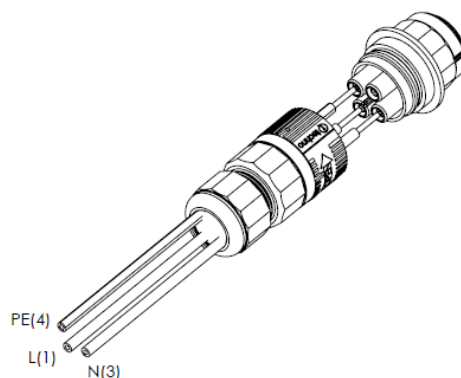

8. CONDITION OF SAFETY USE

- Every light fitting must have rating plates with rating data on it. Each light fitting must have this „Installation and maintenance manual”, which must be kept by user until the end of exploitation.
- Light fittings are designed for fixed installations only.

- Using light fitting outside the designated operating temperature range is unacceptable and will decrease a lifetime of light fitting and/or damage it as well as cause a loss of warranty.
- Each light fitting must have a warning sign: „do not open under voltage” on it.
- For the "24V / 0Hz" version, use as 2-wire supply cables (without a PE wire) with a maximum outer diameter of 8-13mm.
- For the "230V / 0,50-60Hz" version, use as 3-wire supply cables (with PE wire) with a maximum outer diameter of 8-13mm.
- Use power wires with cross section 0,5-1,8mm².
- Maximum cross current I=16A.
- In case the diffuser is made of polycarbonate, so it mustn't be exposed to chemical substances which may destroy it, especially oil, acetone, chloride, ethyl, ether. In case of doubts with substances are in the workplace of light fitting, which can damage the product, the action of fixing should be taken.



- Do not stare at a working light source.



- Risk of electric shock

9. LIGHT FITTING MAINTENANCE AND SERVICING



It is recommended to carry out inspections of electrical equipment in accordance with the requirements of PN-EN 60598-1: 2015-04.

INSPECTION: at least once a month. Inspection is made without opening the light fitting. User must check admission cables condition (insulation damage, cracks, burns etc.). Cables must not have any acute bends. Outside parts of the light fitting must be checked. No cracks or corrosion signs may occur. Bolts used to mount light fitting should be properly tightened, washers mustn't be cracked. Cleanliness of outer surfaces and light fittings surroundings must be checked. Light fittings may not be soiled by paint or grease. Do not allow for dust (dirt) deposition on the light fitting. The readability of rating and warning plates must be checked. Abnormalities found must be fixed.

SERVICE AND MAINTENANCE: at least once a year. Service and maintenance must be made with power supply turned off. User must make inspection steps first. After opening: metal parts painting, condition of inner wiring and its mounting, insulating materials, cable glands gaskets, terminals. Abnormalities found must be fixed. Rating and warning plates must be cleaned. Surfaces of insulating materials and covers must be clean.

VERIFICATION OF TECHNICAL CONDITION: at least once for 2 years. Power supply must be switched off. Light fitting must be uninstalled. Besides all the examination from inspection, service and maintenance paragraphs electrical examination from the inspection, service and maintenance paragraphs electrical examination must be also made: light fitting current consumption, insulation examination, protective earthing condition. Special attention must be paid to insulating parts condition. No crack or burns may occur.

CLEANING: do not allow for dust (dirt) deposition on the light fitting. Cleaning must be proceeded without use of chemical. Cleaning must be proceeded with use of compressed air and soft cleaning cloth

or soft brush. If necessary, use water and/or neutral detergent, however without any chemicals, which can damage any part of the light fitting.

10. PARTS EXCHANGE



All of parts considered as a spare part must be ordered at manufacturer of light fitting.
All repairs can be made only by the manufacturer or an authorized service workshop in accordance with the requirements of PN-EN 60598-1: 2015-04.

11. TRANSPORT AND CONDITIONS OF STORAGE

During transportation light fittings shouldn't be exposed to precipitation or mechanical shock.

Light fittings may be storage only in sheltered warehouses, within +5°C to +35°C temperature range, and relative humidity lower than 75%. No corrosion causing vapors or gases should be present.

12. DISPOSAL OF WASTE EQUIPMENT

User must obey relevant rules and regulations about disposal of wasted equipment valid in their country.

13. WARRANTY

- It is forbidden to use damaged or malfunctioned light fitting.
- It is required to disconnect power supply from the light fitting before any maintenance work.
- It is not allowed to make any changes to the luminaire design. Any unauthorized interference may reduce the functionality or damage the device, and in special cases may be life-threatening or health-threatening. At the same time, any kind of unauthorized changes into the luminaire releases the manufacturer from any warranty liability.
- All specific information can be found in document „General terms and conditions warranty ATM Lighting sp. z o.o.” available at the website www.atmlighting.pl/en/.

DANE ADRESOWE:

ATM Lighting sp. z o.o.

ul. Maszynowa 30A 80-298 Gdańsk

tel: +48 58 347 51 07 fax: +48 58 347 51 08

office[atmlighting].pl