

TUNNEL LIGHT FITTINGS

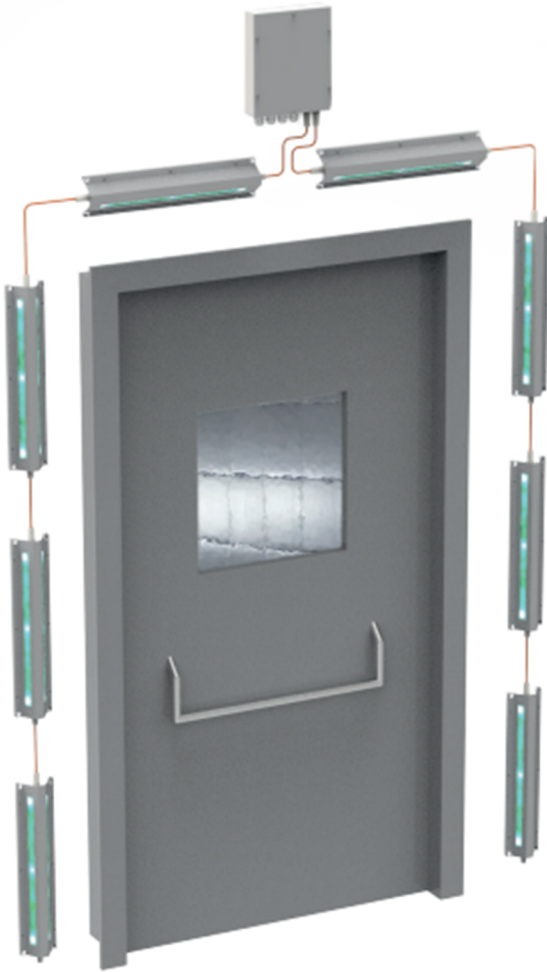

EN-60658-2-22 CERTIFICATE:

CNBOP no. 4470/2021

MECHANICAL PARAMETERS

Housing: stainless steel
Diffuser: tempered glass
Protection level: IP65
Protection class: I
Mountings: mounting holes

OTHER

Lifetime: 70.000 L80 B10
Ambient temperature: -40°C to +45°C

The layout of the elements around the exit door can be modified according to the project specification.

ELECTRICAL PARAMETERS

Source of light: LED modules with ENEC certificate
Voltage: 230V 0/50-60Hz | 230VDC
Cable glands: max 4 x M32
Connection terminals: 7 x 6mm²
Overvoltage protection: 10 kV
Control system: integrated DALI driver



DIMENSIONS

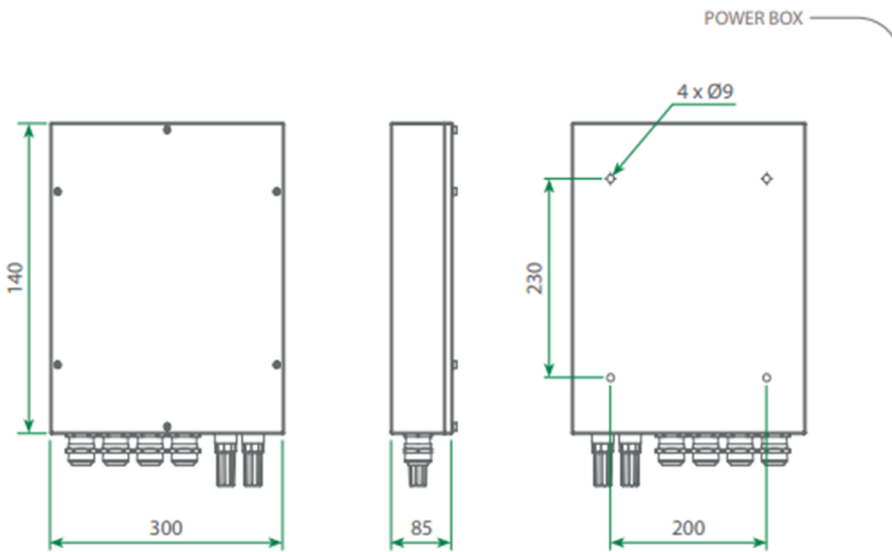
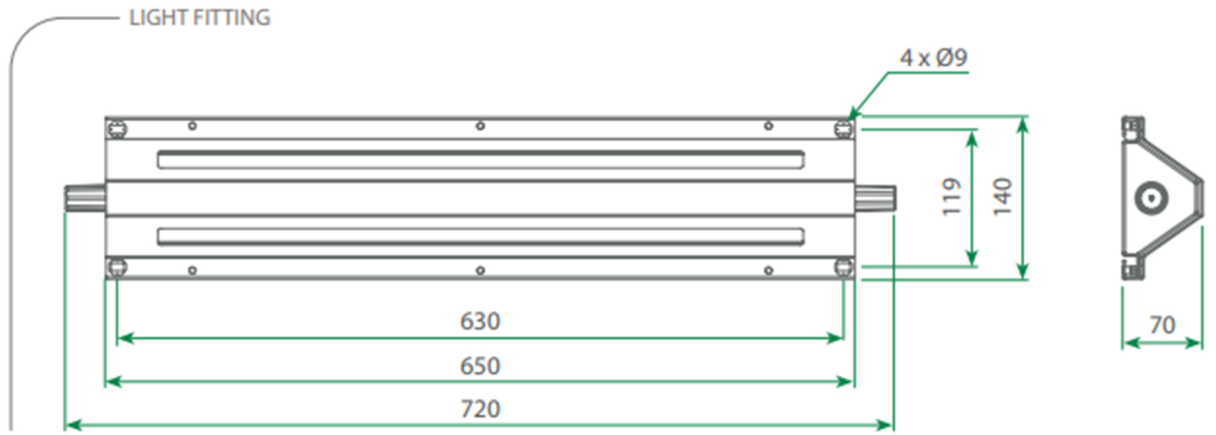

TYPICAL LAYOUT OF THE ELEMENTS OF THE SYSTEM DRAFT

