



INSTALLATION AND MAINTENANCE MANUAL FOR
EXPLOSIONPROOF LIGHT FITTING

EXL390LED



Carefully read the instructions before
mounting the light fitting.

TABLE OF CONTENTS:

1.	GENERAL INFORMATION – PROPER USE	3
2.	TECHNICAL INFORMATION.....	5
3.	PHOTOMETRICAL DATA.....	8
4.	CONSTRUCTION DESCRIPTION.....	8
5.	PRELIMINARIES	9
6.	LIGHT FITTING MOUNTING.....	9
7.	ELECTRICAL CONNECTION.....	9
8.	CONDITIONS OF SAFETY USE	10
9.	LIGHT FITTING MAINTENANCE AND SERVICING	11
10.	CLEANING: EXCHANGE	11
11.	REPAIRING.....	11
12.	LIGHT SOURCE EXCHANGE	12
13.	TRANSPORT AND CONDITIONS OF STORAGE.....	12
14.	DISPOSAL OF WASTE EQUIPMENT.....	12
15.	WARRANTY.....	12

1. GENERAL INFORMATION – PROPER USE

EXL390LED light fittings are designed to light indoor and outdoor areas in zone 2 of explosion hazard of gas, vapors, or clouds of flammable liquids mixed with air which belongs to IIA, IIB or IIC explosion group, T1-T4 temperature class. EXL390 light fittings are also suitable to light areas in zones 21, 22 of explosion hazard of dust and flammable fibers mixed with air which self-ignition temperature is higher than 105°C, and the temperature of glowing layers of dust (5mm) is higher than 145°C.

EXL390LED				E		3	E			20	NIRO				
group						3	4	30	10	M	25		GL	A3	RC
explosionproof light fittings						4	5	40	11	P			PC	ZB	SF
type						6		50						DA	
type 390								60							
source of light								70							
LED modules								80							
approximate length															
– 600mm, 1200mm															
LED modules type															
LED modules quantity															
power supply															
34E - 230V, 50+60Hz															
35E - 230V, 0/50+60Hz															
wiring															
30 - single 3-pole terminal															
40 - single 4-pole terminal															
50 - single 5-pole terminal															
60 - single 6-pole terminal															
70 - single 7-pole terminal															
80 - single 8-pole terminal															
cable inlets - quantity															
10 - one cable inlets on the side of the housing															
11 - two cable inlets on the side and the bottom															
cable in lets - material															
M - metal															
P - plastic															
cable inlets - size															
20 - Ø20															
25 - Ø25															
housing material															
NIRO - stainless steel															
diffuser material															
GL - tempered glass with dust film (MACal® 798-02),															
PC - polycarbonate opal (Exolon® DX White N174)															
emergency versions															
A3 - version with 3h emergency power module available only with 34E power supply (250V, 50-60Hz). Works in the temperature above 0°C.															
ZB - version with driver for central battery															
DA - version with an integrated power supply unit with DALI interface															
mounting															
RC - as a part of the coffer suspended ceiling															
SF - on the ceiling surface															

TECHNICAL INFORMATION

Ex marking:

- For EXL390LED - **** - ** - *** - ** - ***** - **** - ** version



II 3G Ex ec op is IIC T4 Gc
II 2D Ex tb op is IIIC T70°C Db

Interpretation of the use restrictions of the device by means of the symbols in the above marking and on the label of the device:

Name	Symbol	Description
Special explosionproof protection marking		Symbol of device intended for use in potentially explosive atmospheres.
Device group	II	Device intended for use in explosive atmospheres other than underground mine.
Device category	3G	Device can safely operate in zone 2 of the explosion hazard of gases, vapors and mists of flammable liquids with air.
	2D	Device can safely operate in zones 21 or 22 dust explosion hazard.
Type of execution	Ex ec	Device secured with increased safety construction type "e".
	Ex tb	Device secured from dust ignition with the housing type „t”.
Group	IIC	Device can be used in the presence of explosion hazard gases, vapors and mists of flammable liquids with air classified as explosive groups IIA, IIB, IIC.
	IIIC	Device can be used in the presence of explosion hazard of combustible dusts and filaments belonging to explosion groups IIIA, IIIB, IIIC (all types of dusts).
Temperature class	T4	Device intended for use in potentially explosive atmospheres of gases with self-ignition temperature > 135°C
Temperature	T80°C	Device can be used in presence of dusts whose cloud self-ignition temperature is higher than 105°C, and the glowing temperature of the layer (5mm) is higher than 145°C.
Explosion protection level	Gc	Device intended for installation in zone 2 of gas explosion hazard, providing a „normal safety” and which will not become a source of ignition under normal conditions of use and during expected damage.
	Db	Device intended for installation in zones 21, 22 dust explosion hazard, providing a „high level of safety” and which will not become

a source of ignition under normal conditions of use and during expected damage.

Protection degree:	IP65
Cross section admission cable:	1-2.5mm ²
Admission cable diameter::	Ø 8-13mm
Voltage:	230V, 0, 50-60Hz
Protection class:	I
Ambient temperature Ta:	-40°C ... +50°C for all versions
LED module risk group RG=1	

2. TECHNICAL INFORMATION

Type	LED current	Power	Voltage	IP	Protection class	Power factor	Ambient temperature
EXL390LED-0600-E4-1	250 mA	35,0 W	230V 0,50,60Hz	65	I	≥0,97	-40 to +50°C
EXL390LED-0600-E4-3	350 mA	47,0 W					
EXL390LED-1200-E3-1	250 mA	27,1 W					
EXL390LED-1200-E3-3	350 mA	36,6 W					
EXL390LED-1200-E6-1	250 mA	52,0 W					
EXL390LED-1200-E6-3	350 mA	70,5 W					

EXL390LED-0600-E4, standard version + recessed version:

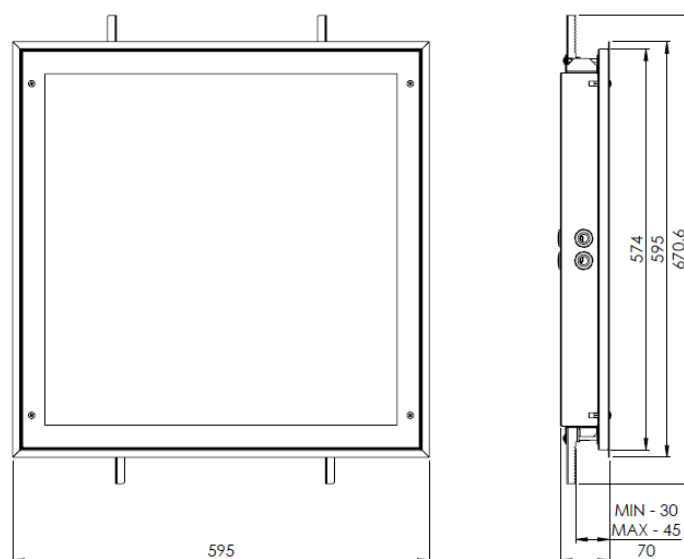

EXL390LED-0600-E4, mounting directly on the ceiling:

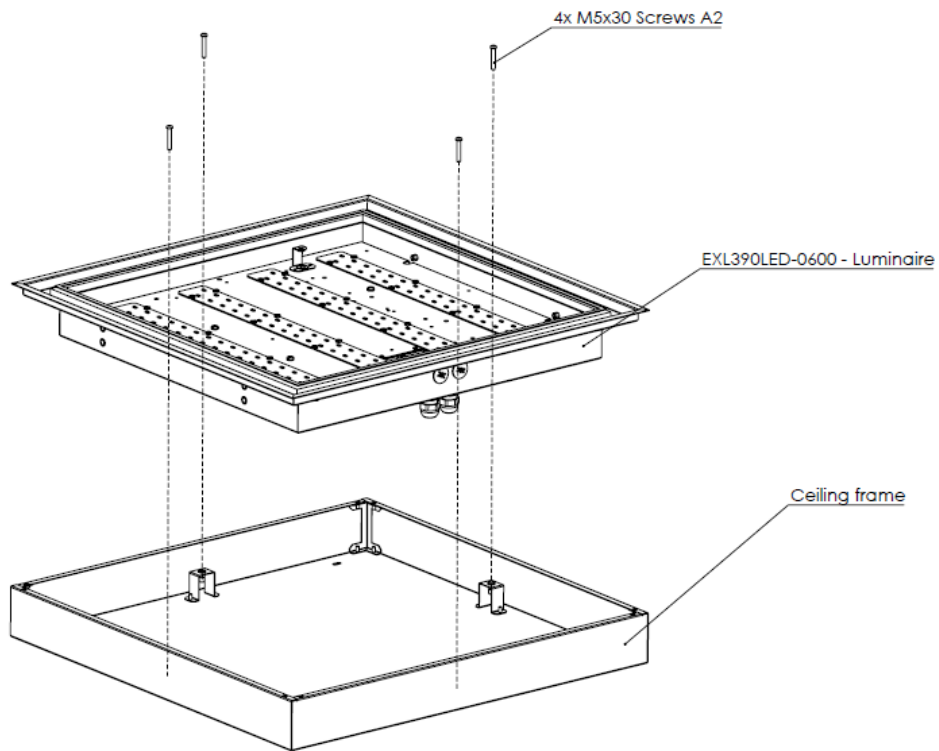
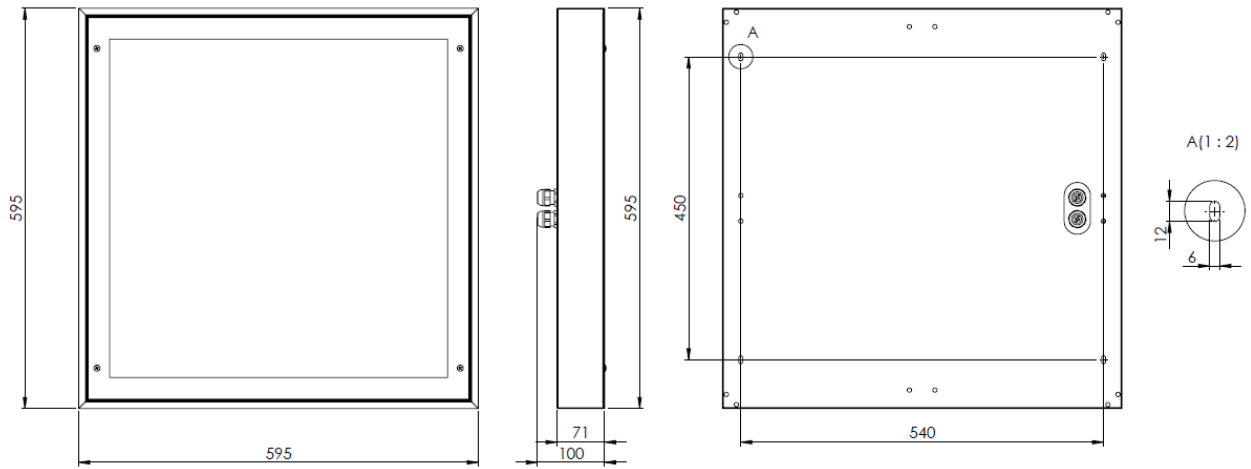

EXL390LED-1200-E3 and EXL390LED-1200-E6, standard version + recessed version:

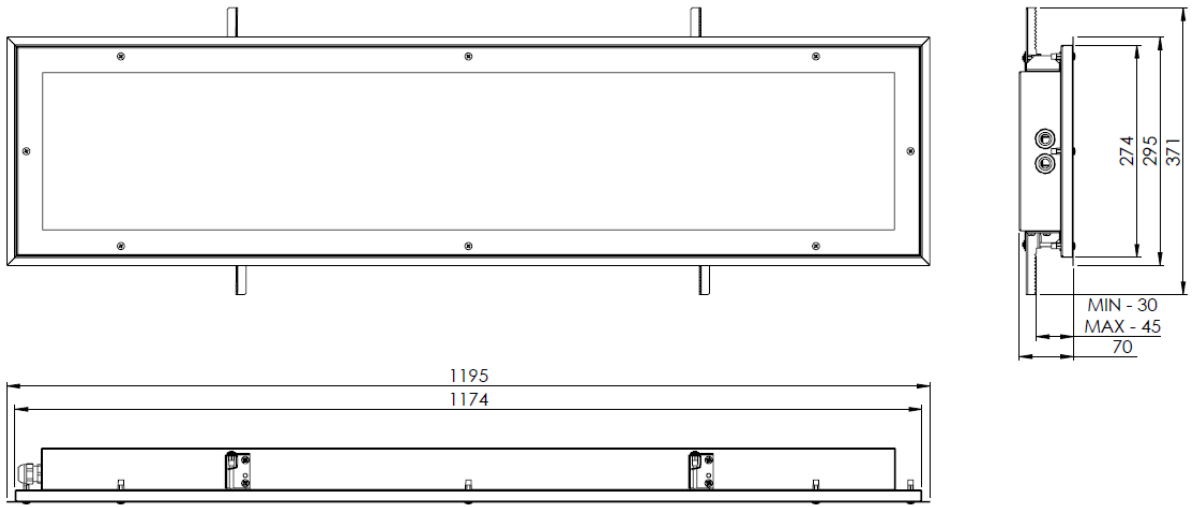

EXL390LED-1200-E3 and EXL390LED-1200-E6, mounting directly on the ceiling:

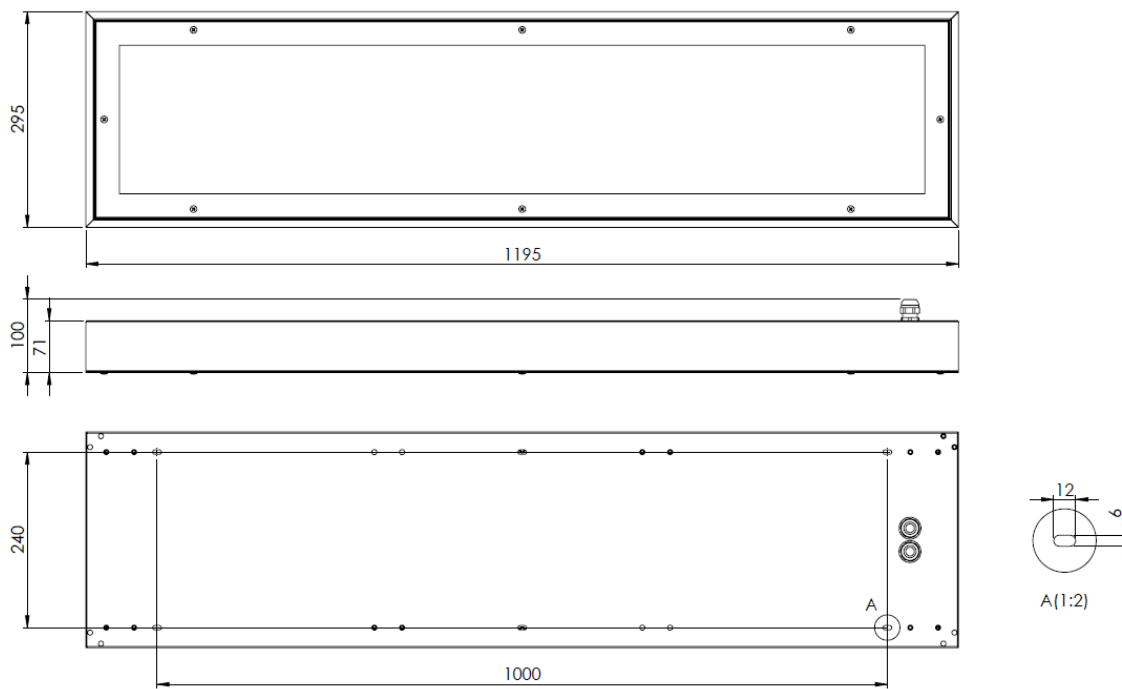

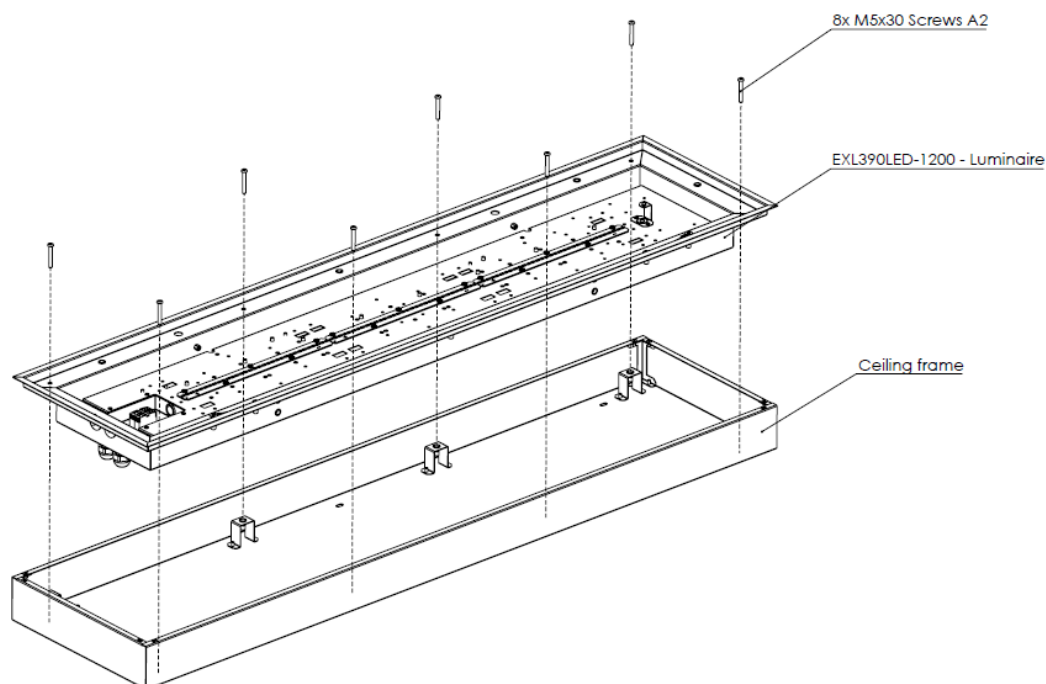

3. PHOTOMETRICAL DATA

Type	LED current	Luminous flux	Efficiency	Colour temperature	CRI	Lifetime
EXL390LED-0600-E4-1	250 mA	4636 lm	132 lm/W	4000K 5000K 6500K	>80	>70.000 h
EXL390LED-0600-E4-3	350 mA	6265 lm	133 lm/W			
EXL390LED-1200-E3-1	250 mA	3160 lm	117 lm/W			
EXL390LED-1200-E3-3	350 mA	4270 lm	117 lm/W			
EXL390LED-1200-E6-1	250 mA	6445 lm	124 lm/W			
EXL390LED-1200-E6-3	350 mA	8710 lm	124 lm/W			

Lifetime of a LED modules: L₈₀B₁₀

4. CONSTRUCTION DESCRIPTION

Light fittings are built according to the PN-EN 60079-0:2013-03+A11:2014-03, PN-EN 60079-15:2010, PN-EN 60079-31:2011 and common electrical engineering rules. Used solutions and materials, electrical equipment and proper insulating spaces makes that during normal exploitation there is no possibility to occur any sparks, electrostatic charge, dangerous heating or light fitting destruction caused by environment factors.

Light fittings are built as a one chamber equipment. Housing is made of powder painted galvanized steel or stainless steel. Mounting tray is made of powder painted galvanized steel.

Used terminals ensures safe and non-sparking connection of inner wires and admission cables. The diffuser is made of UV resistant polycarbonate or tempered glass.

The enclosure of luminaires should be equipped with cable glands and stopping plugs certified as Ex “e” or Ex “d” components, providing IP65, according to requirements of EN 60079-14.

5. PRELIMINARIES

SAFETY RULES

- Carefully read all the information included in the manual before mounting the light fitting.
- General safety rules must be followed.
- Failure to comply with rules of the installation and use can lead to personal injury or property loses. ATM Lighting sp. z o.o. company takes no responsibility in such cases.
- Failure to comply with rules included in manual results with void of the manufacturer warranty.
- Manufacturer takes no responsibility for any damages resulting from improper installation, maintenance or improper use.
- It is the responsibility of the user to perform the installation in accordance with this manual and the safety regulations and standards applicable to the type of installation
- In case of malfunction, the device must be turned off and returned for repair to the manufacturer or his authorized entity.



Before performing any installation work, including opening the enclosure, be absolutely sure to disconnect the unit from the power source.

NECESSARY TOOLS

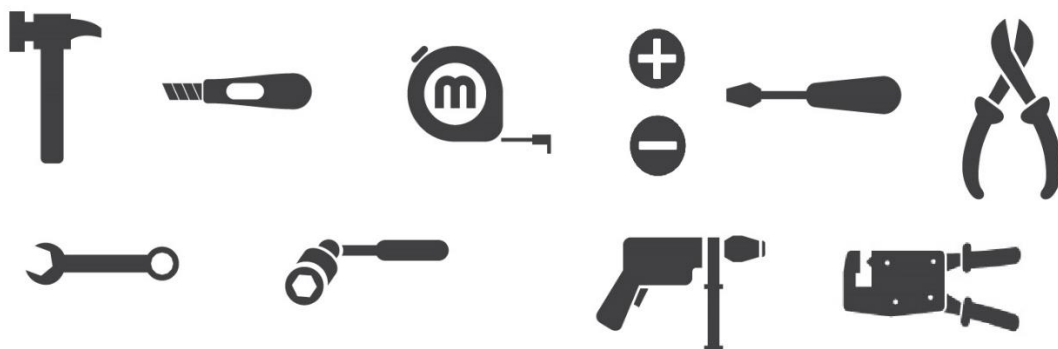

6. LIGHT FITTING MOUNTING

Light fitting is designed for direct installation on a ceiling, modular coffered ceiling or for recessed mounting. Spacing and size of the mounting holes are shown in point 2.

7. ELECTRICAL CONNECTION



Installation and electrical connection should be in accordance with the requirements of PN-EN 60079-14.

To connect power supply:

- enter the power cable to the housing through the cable entry (gland),
- carefully unisolate the wires (8-10mm), and put it into the connector according to a label inside the light fitting,

- precisely tighten power cable in the gland with two wrench,
- check the effectiveness of grounding.

Power connection:

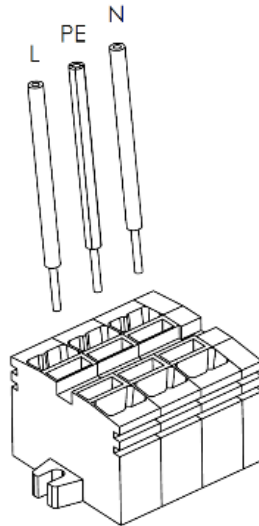

Remarks:

- Use one wrench to tighten the sealing nut, while using the second wrench to block gland body against rotation, otherwise damage of the sealing can be caused and therefore sealing level will be decreased and thus explosion protection.

8. CONDITIONS OF SAFETY USE

- Every light fitting must have label with rating data on it. Each light fitting is equipped with this „Installation and maintenance manual”, which must be kept by user until the end of exploitation.
- Light fittings are designed for fixed installations only.
- Using light fitting outside the designated operating temperature range is unacceptable and will decrease a lifetime of light fitting and/or damage it. It will also cause a loss of warranty.



Remark: Using light fitting beyond the designated operating temperature range may result in the loss of explosion protection measures, such as exceed temperature class and explosion.

- Each light fitting must have a warning sign: „DO NOT OPEN UNDER VOLTAGE” on it.
- Admission cables must have 3-wires (with PE wire) and diameter 8-13mm.
- Use power wires with cross section 1-2,5mm².
- Maximum cross current I=16A.
- The diffuser and housing are made of polycarbonate, so they mustn't be exposed on chemical substances which may destroy it, especially: oil, acetone, chloride, ethyl, ether. In case of doubts with substances present in work environment of light fitting, prior investigation must be made.



- Do not stare into working light source.



- Risk of electrical shock.

9. LIGHT FITTING MAINTENANCE AND SERVICING

REMARK: during the servicing and maintenance touching the LED are prohibited, because it will decrease the lifetime of light fitting and cause the loss of manufacturer's warranty.



It is recommended to carry out inspections of electrical equipment in accordance with the requirements of PN-EN 60079-17.

INSPECTION: at least once a month. Inspection is made without opening the light fitting. User must check admission cables condition (insulation damage, cracks, burns etc.). Cables must not have any acute bends. Outside parts of the light fitting must be checked. No cracks or corrosion signs may occur. Bolts used to mount light fitting should be properly tightened, washers mustn't be cracked. Cleanliness of outer surfaces and light fittings surroundings must be checked. Light fittings may not be soiled by paint or grease. Do not allow for dust (dirt) deposition on the light fitting. The readability of rating and warning plates must be checked. Abnormalities found must be fixed.

SERVICE AND MAINTENANCE: at least once a year. Service and maintenance must be made with power supply turned off. User must make inspection steps first. After opening: metal parts painting, condition of inner wiring and its mounting, insulating materials, cable glands gaskets, terminals. Abnormalities found must be fixed. Rating and warning plates must be cleaned. Surfaces of insulating materials and covers must be clean.

VERIFICATION OF TECHNICAL CONDITION: at least once for 2 years. Power supply must be switched off. Verification of technical condition must be proceeded outside of Ex zone or with monitoring the hazard level. Work can be done if:

- Explosive atmosphere concentration does not exceed 10% of lower explosion limit (LEL) for explosive atmospheres in zones 1 and 2,
- Cleaning activities have been carried out to ensure the cleanliness of the installation (house-keeping) and dust cloud occurrence possibility is excluded in zones 21,22 explosion hazard.

Besides all the examination during inspection, service and maintenance paragraphs electrical examination must be also made: light fitting current consumption, insulation examination, protective earthing condition. Special attention must be paid to insulating parts condition. No crack or burns may occur.

10. CLEANING: EXCHANGE



Do not allow dust to accumulate on the light fitting. Cleaning have to be carried out using vacuum cleaners or a soft cloth with antistatic agent suitable to working conditions. Do not use chemicals that can damage any part of the light fitting.

All parts considered as a spare parts must be ordered at manufacturer of light fitting.

11. REPAIRING



All repairs may be made only by manufacturer or authorized repair workshops according to PN-EN 60079-19.

12. LIGHT SOURCE EXCHANGE

Lamps exchange may be made only by specially trained personnel using the original components provided by ATM Lighting sp. z o.o.

13. TRANSPORT AND CONDITIONS OF STORAGE

During transport light fittings shouldn't be exposed to precipitation or mechanical shock.

Light fittings may be storage only in sheltered warehouses, within +5°C to +35°C temperature range, and relative humidity lower than 75%. No corrosion causing vapors or gases should be present.

14. DISPOSAL OF WASTE EQUIPMENT



User must obey relevant rules and regulations about disposal of wasted equipment valid in their country.

15. WARRANTY

- It is required to disconnect power supply from the light fitting before any maintenance work.
- It is forbidden to make any changes to the light fitting construction. Any unauthorized interference may result in reduced functionality or damage to the device and may in some cases endanger life or health. At the same time it relieves the manufacturer of all warranty liability.
- All specific information can be found in document „General terms and conditions warranty ATM Lighting sp. z o.o.” available at the website www.atmlighting.pl/en/

ADDRESS:

ATM Lighting sp. z o.o.
ul. Maszynowa 30A 80-298 Gdańsk
tel: +48 58 347 51 07
office@atmlighting.pl