



Hazardous
Lighting Solutions LTD



INS3 10LED

Light fitting with LED modules dedicated for food industry and animal husbandry.



MECHANICAL FEATURES

Housing: pressed stainless steel (NIRO)

Diffuser: polycarbonate (PC)

Ingress protection: IP67

Protection class: I

Mounting: direct mounting to ceiling or wall

Access: easy opening

ELECTRICAL FEATURES

Connection terminals: 2.5 mm², 4.0 mm²
(optionally)

Power supply: 35E: 202-240V, 50-60Hz / 220-240V, 0Hz

34E: 220-240V, 50-60Hz

Source of light: certified LED modules

Power factor: >0.95

Cable inlets: Ø20 (wire 8-13 mm)

Overvoltage protection: L-N: 1 kV

L/N-PE: 2 kV

WORK PARAMETERS

Ambient temperature: -25°C to +45°C

(check: types comparison)

Lifetime: >70,000h (L80 B10)

PHOTOMETRICAL PARAMETERS

CRI: >80

Colour temperature: 4000K, 5000K, 6500K

DIMENSIONS

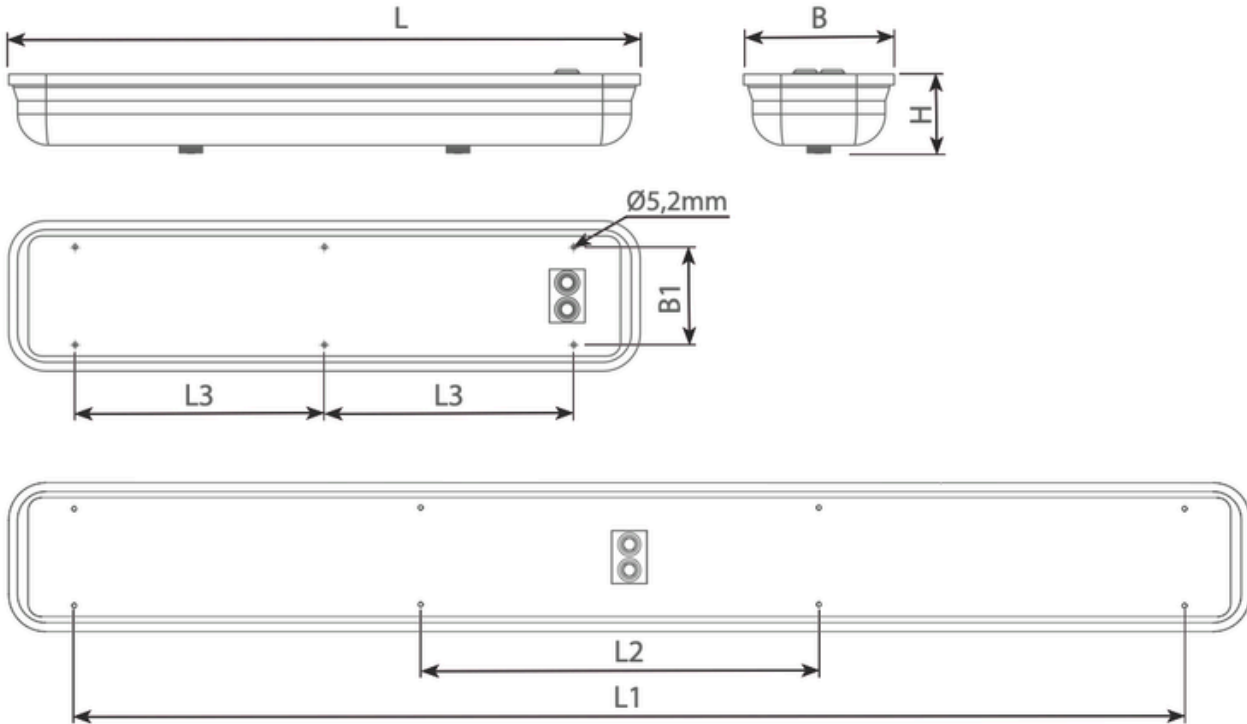

Type	L [mm]	L1 [mm]	L2 [mm]	L3 [mm]	B [mm]	B1 [mm]	H [mm]	Weight [kg]
INS310LED-0600	710	560	–	280	170	110	90	~3.0
INS310LED-1200	1325	1170	390	–	170	110	90	~5.5

TYPE COMPARISONS

Type of the Fitting	Luminous Flux [lm]	Power Consumption [W]	Efficiency [lm/W]	Max. Amb. Temp. [°C]
INS310LED-0600-J2-1	2,250	18.8	120	45
INS310LED-0600-J2-3	3,103	27.2	114	40
INS310LED-1200-J4-1	4,644	36.6	127	45
INS310LED-1200-J4-3	6,155	53.5	115	40
INS310LED-1200-B4-1	10,084	72.1	140	40

EMERGENCY VERSIONS



EMERGENCY POWER MODULE: 3H EMERGENCY POWER MODULE

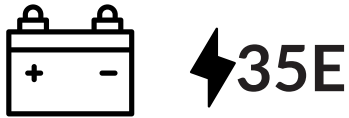

CENTRAL BATTERY: VERSION ADAPTED TO BE POWERED FROM CENTRAL BATTERY WITHOUT SWITCHING MODULE

EMERGENCY VERSIONS LUMINOUS FLUX

Luminaire	34E Version A3 [lm]	35E Version ZB [lm]
INS310LED-0600-J2-1	556	2250
INS310LED-0600-J2-3	526	3103
INS310LED-1200-J4-1	738	4644
INS310LED-1200-J4-3	670	6155
INS310LED-1200-B4-1	816	10084

OPTIONAL EQUIPMENT



DRIVER WITH DALI- 2: VERSION EQUIPPED WITH DALI-2 DRIVER

MAXIMUM NUMBER OF FIXTURES CONNECTED IN LINE

MAXIMUM NUMBER OF LINE CONNECTED LUMINAIRES DEPENDING ON THE USED CIRCUIT BREAKERS

Luminaire	B16	C16
INS310LED	16	26

EMERGENCY VERSIONS



3H ⚡ **34E**

EMERGENCY POWER MODULE: 3H EMERGENCY POWER MODULE

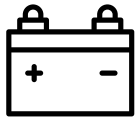

⚡ **35E**

CENTRAL BATTERY: VERSION ADAPTED TO BE POWERED FROM CENTRAL BATTERY WITHOUT SWITCHING MODULE

EMERGENCY VERSIONS LUMINOUS FLUX

Luminaire	34E Version A3 [lm]	35E Version ZB [lm]
INS310LED-0600-J2-1	556	2250
INS310LED-0600-J2-3	526	3103
INS310LED-1200-J4-1	738	4644
INS310LED-1200-J4-3	670	6155
INS310LED-1200-B4-1	816	10084

OPTIONAL EQUIPMENT



DRIVER WITH DALI- 2: VERSION EQUIPPED WITH DALI-2 DRIVER

MAXIMUM NUMBER OF FIXTURES CONNECTED IN LINE

MAXIMUM NUMBER OF LINE CONNECTED LUMINAIRES DEPENDING ON THE USED CIRCUIT BREAKERS

Luminaire	B16	C16
INS310LED	16	26

PHOTOMETRY

